



USER MANUAL

MODELS:

VP-427X

4K HDBT/HDMI Receiver Scaler Switcher

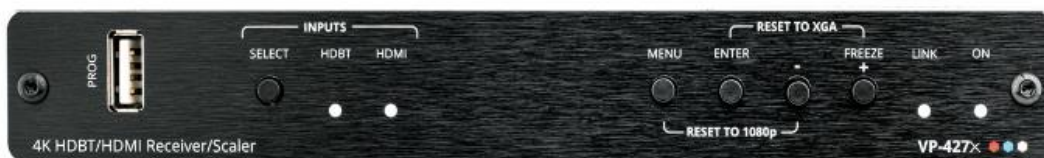

Contents

Introduction	1
Getting Started	1
Overview	2
Typical Applications	3
Defining VP-427X	4
Mounting VP-427X	6
Connecting the 4K HDBT/HDMI Receiver Scaler Switcher	7
Connecting the Output to a Balanced/Unbalanced Stereo Audio Acceptor	8
Connecting to VP-427X via RS-232	8
Wiring RJ-45 Connectors	9
Operating and Controlling VP-427X	10
Principles of Operation	10
Operating and Controlling the Device	10
Using the OSD Menu	11
Controlling VP-427X via the RS-232 Port	19
Upgrading Firmware	20
USB Firmware Upgrade (USB Format FAT32)	20
Technical Specifications	21
Default Communication Parameters	23
Protocol 3000 for VP-427X	24
Understanding Protocol 3000	24
Protocol 3000 Commands	25
Result and Error Codes	32

Introduction

Welcome to Kramer Electronics! Since 1981, Kramer Electronics has been providing a world of unique, creative, and affordable solutions to the vast range of problems that confront the video, audio, presentation, and broadcasting professional on a daily basis. In recent years, we have redesigned and upgraded most of our line, making the best even better!

Getting Started

We recommend that you:

- Unpack the equipment carefully and save the original box and packaging materials for possible future shipment.
- Review the contents of this user manual.



Go to www.kramerav.com/downloads/VP-427X or www.kramerav.com/downloads/VP-427X to check for up-to-date user manuals, application programs, and to check if firmware upgrades are available (where appropriate).

Achieving Best Performance

- Use only good quality connection cables (we recommend Kramer high-performance, high-resolution cables) to avoid interference, deterioration in signal quality due to poor matching, and elevated noise levels (often associated with low quality cables).
- Do not secure the cables in tight bundles or roll the slack into tight coils.
- Avoid interference from neighboring electrical appliances that may adversely influence signal quality.
- Position your Kramer **VP-427X** away from moisture, excessive sunlight and dust.

Safety Instructions



Caution:

- This equipment is to be used only inside a building. It may only be connected to other equipment that is installed inside a building.
- For products with relay terminals and GPIO ports, please refer to the permitted rating for an external connection, located next to the terminal or in the User Manual.
- There are no operator serviceable parts inside the unit.



Warning:

- Use only the power cord that is supplied with the unit.
- To ensure continuous risk protection, replace fuses only according to the rating specified on the product label which is located on the bottom of the unit.

Recycling Kramer Products

The Waste Electrical and Electronic Equipment (WEEE) Directive 2002/96/EC aims to reduce the amount of WEEE sent for disposal to landfill or incineration by requiring it to be collected and recycled. To comply with the WEEE Directive, Kramer Electronics has made arrangements with the European Advanced Recycling Network (EARN) and will cover any costs of treatment, recycling and recovery of waste Kramer Electronics branded equipment on arrival at the EARN facility. For details of Kramer's recycling arrangements in your particular country go to our recycling pages at www.kramerav.com/il/quality/environment.

Overview

Congratulations on purchasing your Kramer **VP-427X 4K HDBT/HDMI Receiver Scaler Switcher**.

VP-427X is a high-performance auto-switcher receiver with integrated scaler for 4K HDMI™ over long-reach HDBaseT, with a local HDMI input and an HDMI output. **VP-427X** receives the HDBaseT signal from a compatible transmitter, converts it to an HDMI signal and up- or down-scales the picture to any resolution up to 4K@60Hz (4:4:4) set by the user or automatically matching the resolution of the display connected to the HDMI output.

Exceptional Quality

- **Auto Switcher Ease of Use** — Automatically plays the switched source signal on the connected display according to user-configured preferences, such as auto-scan or last-connected input. When the user manually switches, by pressing a button, the auto switching is overridden.
- **Fast and clean AV Switching** — Clean and instantaneous switching between inputs, with smooth, fade-through-black, uninterrupted transitions between presented content on the display, greatly enhancing end-users presentation experience.
- **High-Performance Scaling Experience** — Built-in ProcAmp high-resolution scaling technology for optimal up or down image scaling and video signal auto-adjustment with output-connected display capabilities to gain end-users valuable high presentation experience.
- **HDMI Signal Switching** — HDCP 2.2 compliant, supporting deep color, x.v.Color™, CEC, lip sync, HDMI uncompressed audio channels, Dolby TrueHD, DTS-HD, 2K, 4K, and 3D as specified in HDMI 2.0.
- **I-EDIDPro™ Kramer Intelligent EDID Processing™** — Intelligent EDID handling, processing, locking and pass-through algorithm ensures plug & play operation for HDMI source and display systems.

Advanced and User-friendly Operation

- **Display On/Off Operation** — Meeting presentation is simplified by automatically turning ON/OFF a CEC-enabled display when the presentation source is plugged in / unplugged.
- **Convenient Unit Control and Configuration Options** — Local control via front panel

source switching buttons and OSD menu. Distance control via RS–232 serial commands transmitted by a PC, touch screen system or other serial controller.

- Easy, Cost–effective Maintenance — Local firmware upgrade via USB connector.
- Easy and Elegant Installation — Compact MegaTOOLS™ fan–less enclosure for dropped–ceiling mounting, or side–by–side mounting of 2 units in a 1U rack space with the recommended rack adapter

Flexible Connectivity

- Wired and Wireless Auto Switcher — When the receiver is connected to a wireless connectivity device such as Kramer VIA, can automatically select between a wired source at the transmitter or the wireless source at the receiver.
- High Performance Standard Extension — Professional HDBaseT extension for providing long–reach signals over twisted–pair copper infrastructures. VP-427X is a standard receiver that can be connected to any market–available HDBaseT–compliant extension product. For optimum extension reach and performance, use recommended Kramer cables.
- Audio De–embedding — The digital audio signal passing–through to the HDMI output, is de–embedded, converted to an analog signal and sent to the stereo balanced analog audio output. This enables playing the audio on a locally connected professional audio system (such as DSP) and speakers, in parallel to playing it on the speakers connected to the AV acceptor device (such as TVs with speakers).
- Bidirectional RS–232 Extension — Serial interface data flows in both directions, allowing data transmission and device control.

Typical Applications

VP-427X is ideal for the following typical applications:

- Classrooms and lecture halls
- Meeting rooms
- Training facilities
- Collaborative classrooms
- Any space where BYOD support is required

Defining VP-427X

This section defines VP-427X.

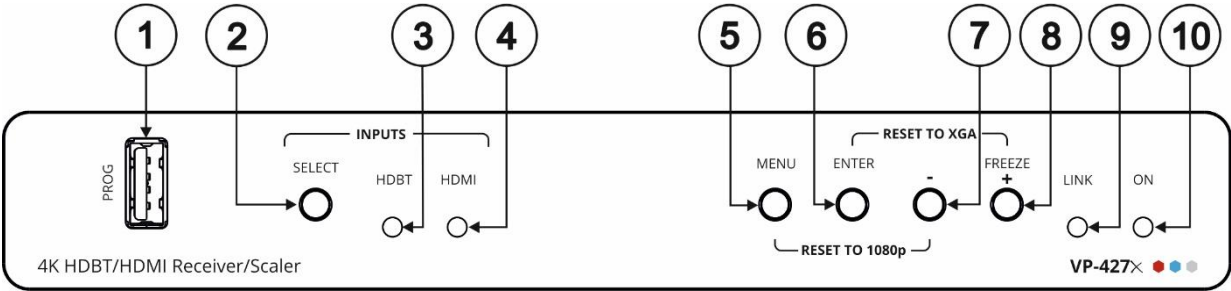

Figure 1: VP-427X 4K HDBT/HDMI Receiver Scaler Switcher Front Panel

#	Feature	Function	
①	PROG USB Connector	Connect to a USB stick to perform firmware upgrades.	
②	INPUTS	SELECT Button	Press to select the input (HDBT or HDMI).
③		HDBT LED	Lights blue when the HDBT input is selected.
④		HDMI LED	Lights blue when the HDMI input is selected.
⑤	MENU Button	Press to enter/exit the on-screen display (OSD) menu. Press together with the – button to reset the output to 1080p resolution.	
⑥	ENTER Button	In OSD, press to choose the highlighted menu item. Press together with the FREEZE/+ button to reset the output to XGA resolution (1024x768).	
⑦	–	In OSD, press to move back through menus or decrement parameter values.	
⑧	FREEZE/+ Button	In OSD, press to move forward through menus or increment parameter values. When not in OSD, press to freeze the display.	
⑨	LINK LED	Lights blue when a link is established with the transmitter.	
⑩	ON LED	Lights green when device is powered.	

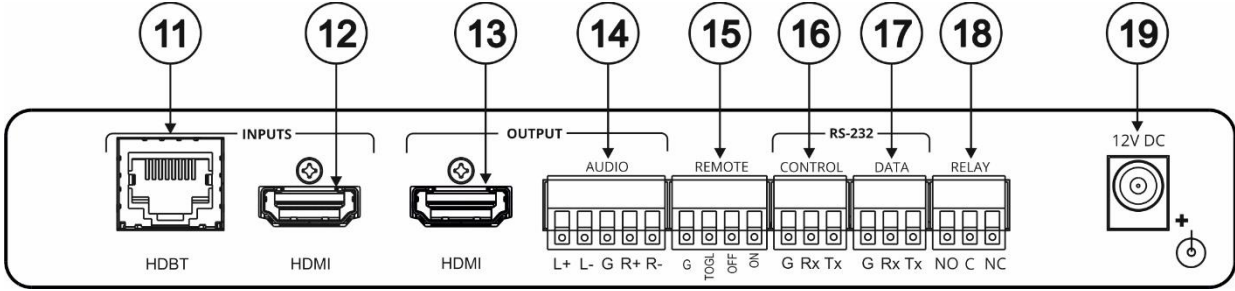

Figure 2: VP-427X 4K HDBT/HDMI Receiver Scaler Switcher Rear Panell

#	Feature	Function
11	INPUTS	HDBT RJ-45 Connector
12		HDMI Connector
13	OUTPUT	HDMI Connector
14		AUDIO 5-pin Terminal Block Connector
15	REMOTE Contact-Closure 4-pin Terminal Block Connector	Connect to contact closure switches, an occupancy sensor and/or toggle switches (contact between the desired pin and GND pin), to turn the display on or off (see Connecting the Remote-Control Switches on page 11).
16	RS-232	CONTROL 3-pin Terminal Block Connector
17		DATA 3-pin Terminal Block Connector
18	RELAY 3-pin Terminal Block Connector	Relay contact pins: normally open (NO), normally closed NC and common (C). Connect to a device to be controlled by a relay (for example, a motorized projection screen).
19	12V DC Connector	Connect to the supplied power adapter.

Mounting VP-427X

This section provides instructions for mounting **VP-427X**. Before installing, verify that the environment is within the recommended range:



- Operation temperature – 0° to 40°C (32 to 104°F).
- Storage temperature – -40° to +70°C (-40 to +158°F).
- Humidity – 10% to 90%, RHL non-condensing.



Caution:

- Mount **VP-427X** before connecting any cables or power.



Warning:

- Ensure that the environment (e.g., maximum ambient temperature & air flow) is compatible for the device.
- Avoid uneven mechanical loading.
- Appropriate consideration of equipment nameplate ratings should be used for avoiding overloading of the circuits.
- Reliable earthing of rack-mounted equipment should be maintained.
- Maximum mounting height for the device is 2 meters.

Mount VP-427X in a rack

- Use the recommended rack adapter (see www.kramerav.com/product/VP-427X).

Mount VP-427X on a surface using one of the following methods:

- Attach the rubber feet and place the unit on a flat surface.
- Fasten a bracket (included) on each side of the unit and attach it to a flat surface (see www.kramerav.com/downloads/VP-427X).

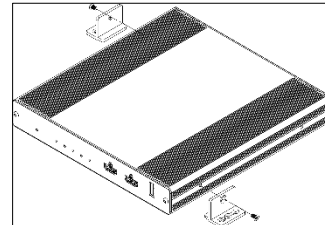

Connecting the 4K HDBT/HDMI Receiver Scaler Switcher



Always switch off the power to each device before connecting it to your **VP-427X**. After connecting your **VP-427X**, connect its power and then switch on the power to each device.

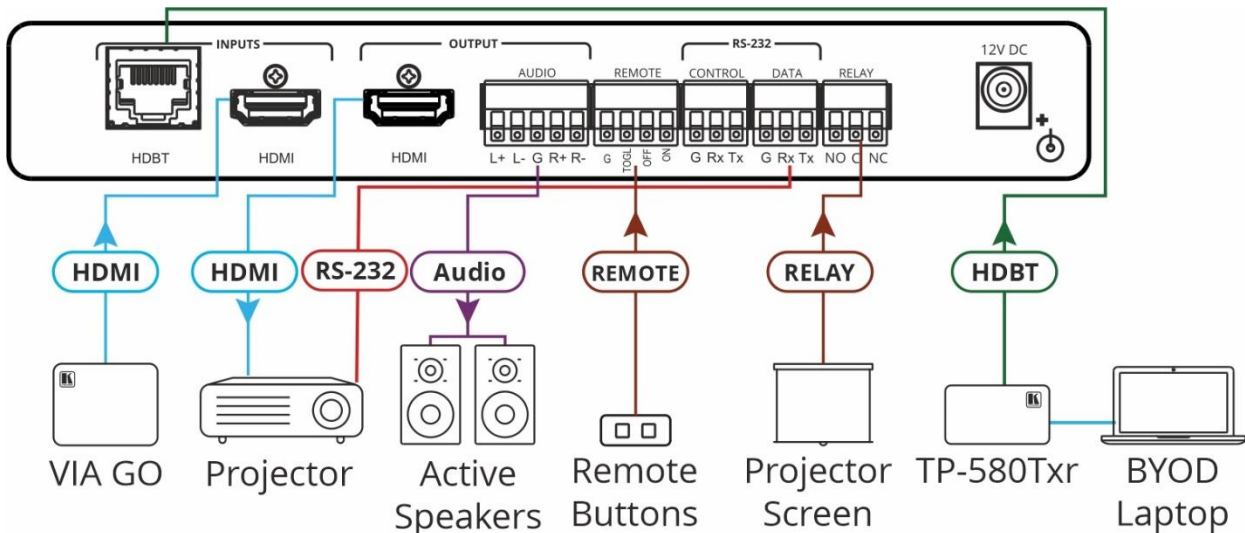

Figure 3: Connecting to VP-427X

To connect VP-427X as illustrated in the example in [Figure 3](#):

1. Connect an HDBT transmitter (for example, Kramer **TP-780T**) to the INPUT HDBT RJ-45 port (11) on the rear panel. The transmitter is connected to a BYOD laptop.
2. Connect an HDMI source (for example, Kramer **VIA GO²**) to the HDMI INPUT connector (12).
3. Connect the HDMI OUT connector (13) to an HDMI Acceptor (for example, a projector).
4. Connect the AUDIO OUT 5-pin terminal block connector (14) to a balanced stereo audio acceptor (for example, Kramer **Tavor 5-O** active speakers).
5. Connect the serially-controlled projector to the RS-232 DATA 3-pin terminal block connector (16) for control via RS-232 from the HDBT transmitter.
6. Connect the REMOTE 4-pin terminal block connector (15) to remote buttons.
7. Connect the RELAY 3-pin terminal block connector (18) to a projector screen
8. Connect the power adapter to the **VP-427X** and plug the adaptor to the mains electricity (not shown in [Figure 3](#)).

Connecting the Output to a Balanced/Unbalanced Stereo Audio Acceptor

The following are the pinouts for connecting the output to a balanced or unbalanced stereo audio acceptor:

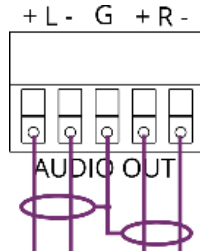

Figure 4: Connecting to a Balanced Stereo Audio Acceptor

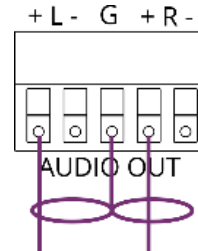

Figure 5: Connecting to an Unbalanced Stereo Audio Acceptor

Connecting to VP-427X via RS-232

You can connect to VP-427X via an RS-232 connection ⁽¹³⁾ using, for example, a PC.

VP-427X features an RS-232 3-pin terminal block connector to extend RS-232 signals via VP-427X transmitter and receiver.

Connect the RS-232 terminal block on the rear panel of VP-427X to a device, as follows:

From the RS-232 9-pin D-sub serial port connect:

- Pin 2 to the TX pin on the VP-427X RS-232 terminal block
- Pin 3 to the RX pin on the VP-427X RS-232 terminal block
- Pin 5 to the G pin on the VP-427X RS-232 terminal block

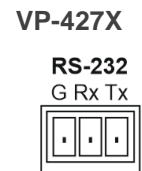
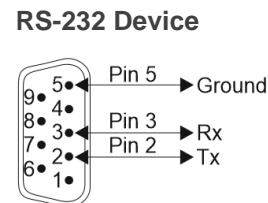

Wiring RJ-45 Connectors

This section defines the HDBT pinout, using a straight pin-to-pin cable with RJ-45 connectors.

 It is recommended that the cable ground shielding be connected/soldered to the connector shield.

EIA /TIA 568B	
PIN	Wire Color
1	Orange / White
2	Orange
3	Green / White
4	Blue
5	Blue / White
6	Green
7	Brown / White
8	Brown

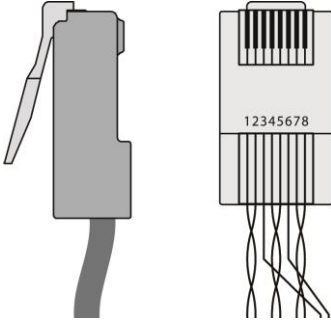

Operating and Controlling VP-427X

Principles of Operation

Flexible Auto Switching Policy

Set the switching policy to:

- Manual – Select an input manually and switching occurs whether a live signal is present on the input or not.
- Auto – Auto Switching selection is performed according to either the Last Connected or the Auto Scan policy.

See [Setting Switching Mode](#) on page [17](#).

OSD Configuration & Operation

Convenient OSD (On Screen Display) menus for easy configuration and switcher operation.

See [Using the OSD Menu](#) on page [11](#).

Auto Display On/Off via CEC

Auto display shut-down and wake-up, via HDMI CEC communication, for energy expenses savings.

See [Defining CEC](#) on page [17](#).



Operating and Controlling the Device

Operate and control VP-427X by:

- [Using the Front Panel Buttons](#) on page [10](#).
- [Connecting the Remote-Control Switches](#) on page [11](#).

Using the Front Panel Buttons

Use VP-427X front panel buttons enable performing the following actions:

- Pressing the **INPUT**  to cycle through and select an input.
- Using the MENU, ENTER (when in the OSD menu), + and – buttons to control the device (see [Using the OSD Menu](#) on page [11](#)).
- Pressing **MENU**  and -  to reset the resolution to 1080p.

- Pressing **ENTER** (6) and **+** (8) to reset the resolution to XGA.
- Pressing **FREEZE** (8) to freeze the image.

Connecting the Remote-Control Switches

Control the display status via remote control switches

Momentarily connect the desired pin to the GND pin to select an input:

Pin Name	Function
TOGL	One button toggles between display on and display off (instead of using two separate buttons for on and off). Alternatively, using the VP-427X OSD, configure turning the display on and off according to whether a switch is open or closed, for example, using an occupancy sensor
OFF	Turn off the display (via CEC).
ON	Turn on the display (via CEC).



Using the OSD Menu

VP-427X enables controlling and defining the device parameters via the OSD, using the front panel MENU buttons.

To enter and use the OSD menu buttons:

1. Press MENU.
2. Press:
 - **ENTER** to accept changes and to change the menu settings.
 - **Arrow buttons** to move through the OSD menu, which is displayed on the video output.
 - **EXIT** to exit the menu.



The default OSD timeout is set to 10 seconds.

OSD Values Table



Default values appear in bold in the following table.

Mode	Function			
PICTURE	CONTRAST	Set the contrast (0~60) (30)		
	BRIGHTNESS	Set the brightness (0~60) (30)		
	FINETUNE	Connector	Function	Parameter
		HDBT/HD MI	HUE	0~60 (30)
SATURATION			0~60 (30)	
SHARPNESS	0~63 (0)			

Mode	Function			
		NOISE REDUCTION	OFF, LOW, MIDDLE, HIGH, AUTO	
	COLOR	Set the red, green, and blue shades 0 to 1023 (512)		
INPUT	SOURCE	Select the source: HDBT, HDMI		
OUTPUT	SIZE	Select the size of display: OVER SCAN, FULL, BEST FIT , PAN SCAN, LETTER BOX, UNDER 2, UNDER 1, FOLLOW IN		
	RESOLUTION	Select the output resolution from the menu (Default, NATIVE)		
		640x480 @60Hz	800x600 @60Hz	1024x768 @60Hz
		1280x768 @60Hz	1280x800 @60Hz	1280x1024 @60Hz
		1360x768 @60Hz	1400x1050 @60Hz	1440x900 @60Hz
		1600x1200 @60Hz	1680x1050 @60Hz	1920x1200 @60Hz RB
		2560x1600 @60Hz RB	1920x1080 @60Hz	1280x720 @60Hz
		2048x1080 @50Hz	2048x1080 @60Hz	2560x1440 @60Hz RB
		3440x1440 @30Hz	3440x1440 @60Hz	720x480P @60Hz
		720x576P @50Hz	1280x72P @50Hz	1280x720P @60Hz
		1920x1080P @24Hz	1920x1080P @25Hz	1920x1080P @30Hz
		1920x1080P @50Hz	1920x1080P @60Hz	2560x1080P @50Hz
		2560x1080P @60Hz	3840x2160P @24Hz	3840x2160P @25Hz
		3840x2160P @30Hz	3840x2160P @50Hz	3840x2160P @60Hz
	Native			
AUDIO	DELAY	OFF,40ms, 110ms, 150ms (40ms)		
	OUTPUT VOLUME	Value 0 ~ 100, (80 = 0db)		
OSD	OFF by default. Set the OSD parameters: H-POSITION; V-POSITION; TIMER 5~60 seconds, OFF (20sec); TRANSPARENCY; DISPLAY (INFO/ON/OFF).			
ADVANCED	HDCP ON HDBT INPUT	ON/OFF		
	HDCP ON HDMI INPUT	ON/OFF		
	HDCP(OUT)	FOLLOW INPUT/FOLLOW OUTPUT		
	AUTO SYNC OFF	DISABLE/SLOW/FAST		
	AUTO SWITCH	OFF/AUTO SCAN/LAST CONNECTED		
	FREEZE	FREEZE + MUTE / ONLY FREEZE / ONLY MUTE		
	EDID MANAGE	Port	EDID Value	
		HDBT EDID	Def. 1080P	
			Def. 4K2K(3G)	
			Def. 4K2K(3G-4:2:0)	
USER1				
USER2				
OUTPUT				
HDMI EDID	Def. 1080P			
	Def. 4K2K(3G)			

Mode	Function	
		Def. 4K2K(3G-4:2:0)
		Def. 4K2K(6G)
		USER1
		USER2
		OUTPUT
	EDID UPLOAD	USER EDID UPLOAD
	TOGGLE PIN	EDGE /ON /OFF / INPUT SELECT
	RELAY	ON/OFF
	OUTPUT CEC BYPASS	ON/OFF
	INFORMATION	Displays the source, the input and output resolution, and the software version.
FACTORY	Reset to factory default parameters (resolution is set to Native).	
EXIT	Select to exit the menu.	

Use the OSD menu to perform the following operations:

- [OSD Values Table](#) on page [11](#).
- [Adjusting Image Parameters](#) on page [14](#).
- [Selecting an Input Signal](#) on page [14](#).
- [Setting Output Parameters](#) on page [15](#).
- [Setting Audio Parameters](#) on page [15](#).
- [Setting OSD Parameters](#) on page [15](#).
- [Managing EDID via OSD](#) on page [15](#).
- [Setting HDCP](#) on page [16](#).
- [Setting Sleep Mode](#) on page [16](#).
- [Setting Switching Mode](#) on page [17](#).
- [Defining FREEZE Button Operation Mode](#) on page [17](#).
- [Defining CEC](#) on page [17](#).
- [Configuring TOGGLE Pin Behavior](#) on page [18](#).
- [Viewing Device Information](#) on page [18](#).
- [Performing a Reset](#) on page [18](#).

Adjusting Image Parameters

VP-427X enables adjusting the image parameters such as contrast, brightness and so on.

To adjust the image parameters:

1. On the front panel press **MENU**. The menu appears.
2. Click **Picture** and define the image parameters according to the information in the OSD Values table (see [OSD Values Table](#) on page [11](#)).

Image parameters are adjusted.

Selecting an Input Signal

Select the VP-427X input source via the OSD menu.

To set the input source:

1. On the front panel press **MENU**. The menu appears.
2. Click **Input** and select the **Source**: HDBT (default) or HDMI.

An input signal is selected.

Setting Output Parameters

VP-427X enables setting output parameters such as the size of the image and output resolution via the OSD MENU buttons.

To set the output parameters:

1. On the front panel press **MENU**. The menu appears.
2. Click **Output** and define the output parameters according to the information in the table.

Image size and output resolution are defined.

Setting Audio Parameters

VP-427X enables defining the audio delay time and output volume.

To set the audio:

1. On the front panel press **MENU**. The menu appears.
2. Click **Audio** and define the following:
 - Set the audio delay time (lip sync) to off, 40ms (default), 110ms or 150ms.
 - Set the AUDIO OUT output volume (default is 80 = 0dB).

Audio parameters are defined.

Setting OSD Parameters

VP-427X enables adjusting OSD parameters for your convenience via the OSD MENU buttons.

To set the OSD parameters:

1. On the front panel press **MENU**. The menu appears.
2. Click **OSD** and define the OSD parameters according to the information in the OSD Values table (see [OSD Values Table](#) on page [11](#)).

OSD parameters are set.

Managing EDID via OSD

VP-427X enables managing the EDID via the OSD MENU buttons.

Uploading the EDID

To upload EDID:

1. On the front panel press **MENU**. The menu appears.
2. Click **Advanced** and select **EDID Manage**. Select the parameters according to the information in the OSD Values table (see [OSD Values Table](#) on page [11](#)).

The selected EDID is sent to the input.

Uploading EDID from an External File

To select the EDID from an external file:

1. Save an EDID file via the EDID webpage.
2. On the front panel press **MENU**. The OSD menu appears.
3. Click **Advanced** and select **EDID Manage**.
4. Select an HDMI input and then select **File**.
The external EDID file (as stored via the EDID embedded page) is stored.

An external EDID file is sent to a selected input.

Setting HDCP

VP-427X enables setting the HDCP on the inputs and on the output via the front panel **MENU** buttons.

To set the HDCP on the inputs and output:

1. On the front panel press **MENU**. The menu appears.
2. Click **Advanced** and define the HDCP parameters according to the information in the OSD Values table (see [OSD Values Table](#) on page 11).

HDCP is set on the input/output.

Setting Sleep Mode

Auto Sync Off turns off the output after a period of not detecting a valid video signal on the input(s) until a valid input is again detected or any keypad button is pressed.

VP-427X enables configuring the Auto Sync Off delay time when a connected display enters sleep mode.

To set Auto Sync Off:

1. On the front panel press **MENU**. The menu appears.
2. Click **Advanced** and select **Auto Sync Off**.
3. Define Auto Sync Off according to the information in the following table:

Menu Item	Function
Off (default)	Leave the outputs active always.
Fast	Disable the outputs after ~ 10 seconds of no input detection.
Slow	Disable the outputs after ~ 2 minutes of no input detection.
Immediate	Disable the outputs immediately.

Sleep mode is defined.

Setting Switching Mode

VP-427X enables configuring for automatic switching of the input source upon signal loss or when a source is plugged in.

To set the switching mode:

1. On the front panel press **MENU**. The menu appears.
2. Click **Advanced** and select **Auto Switching**.
3. Select the switching mode according to the information in the following table:

Menu Item	Function
Off	For manual switching.
Auto Scan	Scans for a valid input when no signal is found on the selected input.
Last Connect	Automatically switches to the last connected input and reverts to the previously selected input after that input is lost.

Switching mode is defined.

Defining FREEZE Button Operation Mode

VP-427X enables defining the function of the FREEZE front panel button (8).

To define the FREEZE button operation mode:

1. On the front panel press **MENU**. The menu appears.
2. Click **Advanced** and select **Freeze**.
3. Set freeze mode according to the information in the following table:

Menu Item	Function
Freeze + Mute	Freeze the image and mute the audio output.
Only Mute	Mute the audio output.
Only Freeze	Freeze the image.

When pressed, FREEZE button functions as defined.

Defining CEC

VP-427X can be configured to automatically send CEC on/off commands to the connected display (default) or to pass CEC commands from the connected source to the connected display.

To set the CEC (Consumer Electronic Control) functionality:

1. On the front panel press **MENU**. The menu appears.
2. Click **Advanced** and select **Output CEC Bypass**.
3. Select:
 - **Off** – Automatically send CEC commands to shut down the output display after a timeout period when no input signal is found and to power up the display when the input returns.
 - **On** – Pass CEC commands from the source to the display.

CEC functionality is defined.

Configuring TOGGLE Pin Behavior

VP-427X enables defining the function of the REMOTE pin (15) on the rear panel.

To configure the TOGGLE pin (see [Connecting the Remote-Control Switches](#) on page 11):

1. On the front panel press **MENU**. The menu appears.
2. Click **Advanced** and select **Toggle Pin**.
3. Select the TOGGLE pin configuration:
 - Edge = (toggle on/off).
 - Input Select.
 - GND=Off / Hi=On
 - GND=On / Hi=Off
 - Hi=Off

Viewing Device Information

Device information includes the selected source, the input and output resolutions, and the software version.

To view the information:

1. On the front panel press **MENU**. The menu appears.
2. Click **INFO** and view the input resolution, output resolution and software version.

Information is displayed.

Performing a Reset

VP-427X enables performing either a soft reset or a full reset via the front panel MENU buttons.

To reset the device:

1. On the front panel press **MENU**. The menu appears.
2. Click **Factory** and select either Reset (full reset) or a Soft Reset (reset device information excluding Ethernet parameters), then click **Yes**.
Wait for completion of factory reset (resolution is set to Native).

Device is reset.

Controlling VP-427X via the RS-232 Port

Connect the RS-232 port to a system controller to control the VP-427X.

To control VP-427X via RS-232:

1. Connect a controlling system to the RS-232 CONTROL port (see [Connecting to VP-427X via RS-232](#) on page 8).

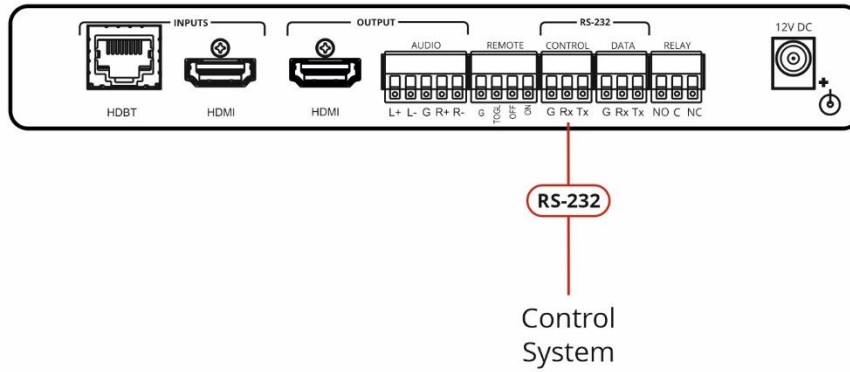

Figure 6: Local Scaler Control

RS-232 port is used to control the VP-427X.

Upgrading Firmware

Upgrade the firmware in any of the following ways:

- Connecting the device to your PC and using Kramer **K-UPLOAD** software.
- Via PROG USB port ① (see [USB Firmware Upgrade \(USB Format FAT32\)](#) on page [20](#)).

USB Firmware Upgrade (USB Format FAT32)

To update the firmware via PROG USB port:

1. Save VP_427X bin. file (for example, VP_427X_all_V*.bin) in USB flash driver and plug into PROG USB port.
2. Press and hold MENU+ENTER buttons for about 3 seconds until both HDBT/HDMI INPUT LEDs blink.
3. Continue holding buttons until both LEDs are lit consistently (this could take up to 60 seconds).
4. Set the unit to factory reset (MENU>FACTORY>RESET ALL).
5. Power off and remove the USB flash driver.



If the device is in USB mode but can't read the firmware file or if the USB flash driver is not connected, it reboots automatically after 10 seconds and exits the USB mode.



If the power drops during firmware upgrade, it automatically starts upgrading once the power is back.

If the power drops in the early stages of firmware upgrade, you need to start firmware upgrade again.

Technical Specifications

Inputs	HDBaseT	On an RJ-45 female connector
	HDMI	On a female HDMI connector
Outputs	HDMI	On a female HDMI connector
	Balanced Analog Stereo Audio	On a 5-pin terminal block connector
Ports	1 Control RS-232	On a 3-pin terminal block connector for device control
	1 Data RS-232	On a 3-pin terminal block connector for serial extension
	3 Remote Contact-Closure	On a 4 pin terminal block connector
	1 Relay	On a 3-pin terminal block connector
	1 Program USB	On a USB-A connector for firmware upgrade
Video	Max. Data rate	18Gbps
	Max. Resolution	4K @60Hz (4:4:4)
	Max Frame Latency	2
	Content Protection	HDCP 2.2, 1.4
	Max Inputs Switching Time	2.5sec (constant output sync)
	Output Resolutions	640x480@60Hz, 800x600@60Hz, 1024x768@60Hz, 1280x768@60Hz, 1280x800@60Hz, 1280x1024@60Hz, 1360x768@60Hz, 1400x1050@60Hz, 1440x900@60Hz, 1600x1200@60Hz, 1680x1050@60Hz, 1920x1200@60Hz RB, 2560x1600@60Hz RB, 1920x1080@60Hz, 1280x720@60Hz, 2048x1080@50/60Hz, 2560x1440@60Hz RB, 720x480p@60Hz, 720x576p@50Hz, 1280x720p@50/60Hz, 1920x1080p@24/25/30/50/60Hz, 2560x1080p@50/60Hz, 2K@24/25/30/50/60Hz, 4K@24/25/30/50/60Hz
Compliance	4K60, CEC, xvYCC color per HDMI 2.0	
Extension Line	Reach	4K@60Hz (4:2:0): 40m (130ft) 1080p@60Hz: 70m (230ft)
	Max Data Rate	10Gbps
	Max. Resolution	4K @60Hz (4:2:0)
	Compliance	HDBaseT 1.0
Audio	Output Impedance	500Ω
	S/N Ratio	>95dB (A-Weighted)
	THD+Noise	<0.003% @1kHz at 1Vpp
	Crosstalk	<-94dB @1kHz
	Output coupling	DC
	Maximum Output Level	14dBu
Extended RS-232	Baud Rate	300 to 115200
Control RS-232	Baud Rate	115200 baud
Power	Source	2A/12V
	Consumption	1A
Enclosure	Size	MegaTOOLS®
	Type	Aluminum
	Cooling	Convection Ventilation
	Operating Temperature	0° to +40°C (32° to 104°F)

Environmental Conditions	Storage Temperature	-40° to +70°C (-40° to 158°F)
	Humidity	10% to 90%, RHL non-condensing
Regulatory Compliance	Safety	CE, FCC
	Environmental	RoHs, WEEE
General	Net Dimensions (W, D, H)	18.8cm x 14.5cm x 2.54cm (7.4" x 5.7" x 1")
	Shipping Dimensions (W, D, H)	35.1cm x 21.2cm x 7.2cm (13.8" x 8.4" x 2.8")
	Net Weight	0.9kg (2.0lbs) approx.
	Shipping Weight	1.1kg (2.4lbs) approx.
Accessories	Included	Power cord and adapter
Specifications are subject to change without notice at www.kramerav.com		

Default Communication Parameters

RS-232	
Baud Rate:	115,200
Data Bits:	8
Stop Bits:	1
Parity:	None
Command Format:	ASCII
Example (Route video HDBT INPUT to HDMI OUTPUT):	#ROUTE_1,1,1<CR>
Ethernet	
To reset the IP settings to the factory reset values go to: Menu->Setup -> Factory Reset-> press Enter to confirm	
IP Address:	192.168.1.39
Subnet mask:	255.255.0.0
Default gateway:	192.168.0.1
TCP Port #:	5000
UDP Port #:	50000
Default username:	Admin
Default password:	Admin
Factory Reset	
OSD	Go to: Menu > Factory > select either Reset (full reset) or a Soft Reset (reset device information excluding Ethernet parameters).
Front panel buttons	Press the Reset to XGA/1080p Button while plugging the power to reset the machine.
Embedded web pages	Device Settings > Soft Factory Reset.

Protocol 3000 for VP-427X

Kramer devices can be operated using Kramer Protocol 3000 commands sent via serial or Ethernet ports.

Understanding Protocol 3000

Protocol 3000 commands are a sequence of ASCII letters, structured according to the following.

- **Command format:**

Prefix	Command Name	Constant (Space)	Parameter(s)	Suffix
#	Command	_	Parameter	<CR>

- **Feedback format:**

Prefix	Device ID	Constant	Command Name	Parameter(s)	Suffix
~	nn	@	Command	Parameter	<CR><LF>

- **Command parameters** – Multiple parameters must be separated by a comma (,). In addition, multiple parameters can be grouped as a single parameter using brackets ([and]).
- **Command chain separator character** – Multiple commands can be chained in the same string. Each command is delimited by a pipe character (|).
- **Parameters attributes** – Parameters may contain multiple attributes. Attributes are indicated with pointy brackets (<...>) and must be separated by a period (.).

The command framing varies according to how you interface with **VP-427X**. The following figure displays how the # command is framed using terminal communication software (such as Hercules):

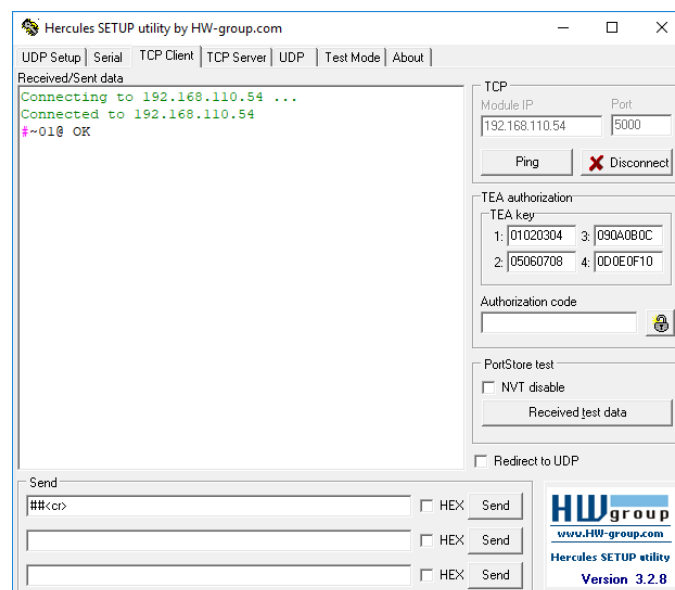



Protocol 3000 Commands

Function	Description	Syntax	Parameters/Attributes	Example
#	Protocol handshaking.  Validates the Protocol 3000 connection and gets the machine number. Step-in master products use this command to identify the availability of a device.	COMMAND #<CR> FEEDBACK ~nn@ok<CR><LF>		#<CR>
AUD-LVL	Set volume level.	COMMAND #AUD-LVL _{io_mode,io_index,vol_level} <CR> FEEDBACK ~nn@AUD-LVL _{io_mode,io_index,vol_level} <CR><LF>	io_mode – Input/Output 1 – Output io_index – Number that indicates the specific input or output port: 1 – AUDIO OUTPUT vol_level – Volume level 0 to 100; ++ (increase current value by 1); -- (decrease current value by 1)	Set AUDIO OUTPUT level to 50: #AUD-LVL _{1,1,50} <CR>
AUD-LVL?	Get volume level.	COMMAND #AUD-LVL? _{io_mode,io_index} <CR> FEEDBACK ~nn@AUD-LVL _{io_mode,io_index,vol_level} <CR><LF>	io_mode – Input/Output 1 – Output io_index – Number that indicates the specific input or output port: 1 – AUDIO OUTPUT vol_level – Volume level 0 to 100	Get AUDIO OUT 1 level #AUD-LVL? _{1,1} <CR>
AV-SW-MODE	Set input auto switch mode (per output).	COMMAND #AV-SW-MODE _{layer_type,out_index,connection_mode} <CR> FEEDBACK ~nn@AV-SW-MODE _{layer_type,out_index,connection_mode} <CR><LF>	layer_type – Number that indicates the signal type: 1 – Video out_index – Number that indicates the specific output: 1 – HDMI OUTPUT connection_mode – Connection mode 0 – manual 1 – auto scan 2 – last connected	Set input auto switch mode (per output) for audio 1 to manual: #AV-SW-MODE _{1,1,0} <CR>
AV-SW-MODE?	Get input auto switch mode (per output).	COMMAND #AV-SW-MODE? _{layer_type,out_index} <CR> FEEDBACK ~nn@AV-SW-MODE _{layer_type,out_index,connection_mode} <CR><LF>	layer_type – Number that indicates the signal type: 1 – Video out_index – Number that indicates the specific output: 1 – HDMI OUTPUT connection_mode – Connection mode 0 – manual 1 – auto scan 2 – last connected	Get the input audio switch mode for HDBT Out: #AV-SW-MODE? _{1,1} <CR>
BUILD-DATE?	Get device build date.	COMMAND #BUILD-DATE? _{date,time} <CR> FEEDBACK ~nn@BUILD-DATE _{date,time} <CR><LF>	date – Format: YYYY/MM/DD where YYYY = Year MM = Month DD = Day time – Format: hh:mm:ss where hh = hours mm = minutes ss = seconds	Get the device build date: #BUILD-DATE? _{date,time} <CR>
CEC	Set display to ON/OFF	COMMAND #CEC _{state} <CR> FEEDBACK ~nn@CEC _{state} <CR><LF>	state – CEC state 0 – Off 1 – On	Set display to OFF via CEC: #CEC-ON<CR>
CEC-PASS	Set CEC device bypass.	COMMAND #CEC-PASS _{state} <CR> FEEDBACK ~nn@CEC-PASS _{state} <CR><LF>	state – CEC state 0 – Off 1 – On	Bypass device: #CEC-PASS ₁ <CR>

Function	Description	Syntax	Parameters/Attributes	Example
CPEDID	<p>Copy EDID data from the output to the input EEPROM.</p> <p>i Destination bitmap size depends on device properties (for 64 inputs it is a 64-bit word).</p> <p>Example: bitmap 0x0013 means inputs 1,2 and 5 are loaded with the new EDID.</p> <p>In certain products Safe_mode is an optional parameter. See the HELP command for its availability.</p>	<p>COMMAND <code>#CPEDID_edid_io,src_id,edid_io,dest_bitmap<CR></code> or <code>#CPEDID_edid_io,src_id,edid_io,dest_bitmap,safe_mode<CR></code></p> <p>FEEDBACK <code>~nn@CPEDID_edid_io,src_id,edid_io,dest_bitmap<CR><LF></code> <code>~nn@CPEDID_edid_io,src_id,edid_io,dest_bitmap,safe_mode<CR><LF></code></p>	<p>edid_io – EDID source type (usually output) 1 – Output src_id – Number of chosen source stage 1=Def. 1080P 2=Def. 4K2K(3G) 3=Def. 4K2K(3G-4:2:0) 4=USER1 5=USER2 6=OUTPUT 7= Def. 4K2K(6G) – for HDMI only (not relevant for HDBT)</p> <p>edid_io – EDID destination type (usually input) 0 – Input</p> <p>dest_bitmap – Bitmap representing destination IDs. Format: XXXX...X, where X is hex digit. The binary form of every hex digit represents corresponding destinations. 0 – indicates that EDID data is not copied to this destination. 1 – indicates that EDID data is copied to this destination.</p> <p>safe_mode – Safe mode 0 – device accepts the EDID as is without trying to adjust 1 – device tries to adjust the EDID (default value if no parameter is sent)</p>	<p>Copy the EDID data from USER1 to the Input: <code>#CPEDID_1,4,0,0x01<CR></code></p> <p>Copy the EDID data from the default EDID source to the Input: <code>#CPEDID_1,1,0,0x01<CR></code></p>
DISPLAY?	Get output HPD status.	<p>COMMAND <code>#DISPLAY?_out_index<CR></code></p> <p>FEEDBACK <code>~nn@DISPLAY_out_index,status<CR><LF></code></p>	<p>out_index – Number that indicates the specific output: 1 – HDMI OUTPUT</p> <p>status – HPD status according to signal validation 0 – Signal or sink is not valid 1 – Signal or sink is valid 2 – Sink and EDID is valid</p>	Get the output HPD status of HDMI OUTPUT: <code>#DISPLAY?_1<CR></code>
FCT-SN	Set serial number.	<p>COMMAND <code>#FCT-SN_serial_num<CR></code></p> <p>FEEDBACK <code>~nn@FCT-SN_serial_num<CR><LF></code></p>	serial_num – 14 decimal digits	Set serial number: <code>#FCT-SN_19763840581123<CR></code>
HDCP-MOD	<p>Set HDCP mode.</p> <p>i Set HDCP working mode on the device input:</p> <p>HDCP supported - HDCP_ON [default].</p> <p>HDCP not supported - HDCP OFF.</p> <p>HDCP support changes following detected sink - MIRROR OUTPUT.</p> <p>When you define 3 as the mode, the HDCP status is defined according to the connected output in the following priority: OUT 1, OUT 2. If the connected display on OUT 2 supports HDCP, but OUT 1 does not, then HDCP is defined as not supported. If OUT 1 is not connected, then HDCP is defined by OUT 2.</p>	<p>COMMAND <code>#HDCP-MOD_in_index,mode<CR></code></p> <p>FEEDBACK <code>~nn@HDCP-MOD_in_index,mode<CR><LF></code></p>	<p>in_index – Number that indicates the specific input: 1 – HDBT INPUT 1 – HDMI INPUT</p> <p>mode – HDCP mode: 0 – HDCP Off 1 – HDCP On</p>	Set the input HDCP-MODE of HDBT INPUT to Off: <code>#HDCP-MOD_1,0<CR></code>
HDCP-MOD?	<p>Get HDCP mode.</p> <p>i Set HDCP working mode on the device input:</p> <p>HDCP supported - HDCP_ON [default].</p> <p>HDCP not supported - HDCP OFF.</p> <p>HDCP support changes following detected sink - MIRROR OUTPUT.</p>	<p>COMMAND <code>#HDCP-MOD?_in_index<CR></code></p> <p>FEEDBACK <code>~nn@HDCP-MOD_in_index,mode<CR><LF></code></p>	<p>in_index – Number that indicates the specific input: 1 – HDBT INPUT 2 – HDMI INPUT</p> <p>mode – HDCP mode: 0 – HDCP Off 1 – HDCP On</p>	Get the input HDCP-MODE of HDMI INPUT: <code>#HDCP-MOD?_2<CR></code>

Function	Description	Syntax	Parameters/Attributes	Example
HELP	Get command list or help for specific command.	COMMAND #HELP<CR> #HELP_<cmd_name><CR> FEEDBACK 1. Multi-line: ~nn@Device_<cmd_name>,<cmd_name>.<CR><LF> To get help for command use: HELP (COMMAND_NAME)<CR><LF> ~nn@HELP_<cmd_name>:<CR><LF> description<CR><LF> USAGE:usage<CR><LF>	cmd_name – Name of a specific command	Get the command list: #HELP<CR> To get help for AV-SW-TIMEOUT: HELP_av-sw-timeout<CR>
MODEL?	Get device model. ⓘ This command identifies equipment connected to VP-427X and notifies of identity changes to the connected equipment. The Matrix saves this data in memory to answer REMOTE-INFO requests.	COMMAND #MODEL?_<CR> FEEDBACK ~nn@MODEL_<model_name><CR><LF>	model_name – String of up to 19 printable ASCII chars	Get the device model: #MODEL?_<CR>
MUTE	Set audio mute.	COMMAND #MUTE_<out_index>,<mute_mode><CR> FEEDBACK ~nn@MUTE_<out_index>,<mute_mode><CR><LF>	out_index – Number that indicates the specific output: 1 – AUDIO OUTPUT mute_mode – On/Off 0 – Off 1 – On	Set AUDIO OUTPUT to mute: #MUTE_1,1<CR>
MUTE?	Get audio mute.	COMMAND #MUTE?_<out_index><CR> FEEDBACK ~nn@MUTE_<out_index>,<mute_mode><CR><LF>	out_index – Number that indicates the specific output: 1 – AUDIO OUTPUT mute_mode – On/Off 0 – Off 1 – On	Get mute status of AUDIO OUTPUT #MUTE_1?<CR>
PROT-VER?	Get device protocol version.	COMMAND #PROT-VER?_<CR> FEEDBACK ~nn@PROT-VER_3000:version<CR><LF>	version – XX.XX where X is a decimal digit	Get the device protocol version: #PROT-VER?_<CR>
RELAY-STATE	Set relay state.	COMMAND #RELAY-STATE_<relay_id>,<state><CR> FEEDBACK ~nn@RELAY-STATE_<relay_id>,<state><CR><LF>	relay_id – Relay number 1 state – Relay state 0 – (open) 1 – (close)	Set relay to closed: #RELAY-STATE_1,1<CR>
RELAY-STATE?	Get relay state.	COMMAND #RELAY-STATE?_<relay_id><CR> FEEDBACK ~nn@RELAY-STATE_<relay_id>,<relay_state><CR><LF>	relay_id – Relay number 1 relay_state – Relay state 0 – (open) 1 – (close)	Get relay state: #RELAY-STATE?_1<CR>
RESET	Reset device. ⓘ To avoid locking the port due to a USB bug in Windows, disconnect USB connections immediately after running this command. If the port was locked, disconnect and reconnect the cable to reopen the port.	COMMAND #RESET<CR> FEEDBACK ~nn@RESET_ok<CR><LF>		Reset the device: #RESET<CR>
ROUTE	Set layer routing. ⓘ This command replaces all other routing commands.	COMMAND #ROUTE_<layer_type>,<out_index>,<in_index><CR> FEEDBACK ~nn@ROUTE_<layer_type>,<out_index><CR><LF>	layer_type Layer Enumeration 1 – Video out_index (both selections are identical) 1 – HDMI OUTPUT * – ALL in_index – Source id 1 – HDBT INPUT 2 – HDMI INPUT	Route video HDBT INPUT to HDMI OUTPUT: #ROUTE_1,1,1<CR>
ROUTE?	Get layer routing. ⓘ This command replaces all other routing commands.	COMMAND #ROUTE?_<layer_type>,<out_index><CR> FEEDBACK ~nn@ROUTE_<layer_type>,<out_index>,<in_index><CR><LF>	layer_type Layer Enumeration 1 – Video out_index (both selections are identical) 1 – HDMI OUTPUT * – ALL in_index – Source id 1 – HDBT INPUT 2 – HDMI INPUT	Get the layer routing: #ROUTE?_1,*,*<CR>
SCLR-AS	Set auto-sync features. ⓘ Sets the auto sync features for the selected scaler.	COMMAND #SCLR-AS_<scaler_index>,<sync_speed><CR> FEEDBACK ~nn@SCLR-AS_<scaler_index>,<sync_speed><CR><LF>	scaler_index – Scaler Number: 1 – Scaler1 sync_speed – 0, 1 or 2 0 – off 1 – fast 2 – slow	Set auto-sync feature to fast: #SCLR-AS_1,1<CR>
SCLR-AS?	Get auto-sync features. ⓘ Gets the auto sync features for the selected scaler.	COMMAND #SCLR-AS?_<scaler_index><CR> FEEDBACK ~nn@SCLR-AS_<scaler_index>,<sync_speed><CR><LF>	scaler_index – Scaler Number: 1 – Scaler1 sync_speed – 0, 1 or 2 0 – off 1 – fast 2 – slow	Get auto-sync features: #SCLR-AS?_1<CR>

Function	Description	Syntax	Parameters/Attributes	Example
SCLR-AUDIO-DELAY	Set the scaler audio delay.  Sets the audio delay for the selected audio output.	COMMAND #SCLR-AUDIO-DELAY<scaler_index>,delay<CR> FEEDBACK ~nn@SCLR-AUDIO-DELAY<scaler_index>,delay<CR><LF>	scaler_index – Audio output number 1 – Scaler1 delay – 0 – Off 1 – 40ms 2 – 110ms 3 – 150ms	Set the scaler audio delay 40ms: #SCLR-AUDIO-DELAY_1,1<CR>
SCLR-AUDIO-DELAY?	Get the scaler audio delay.  Gets the audio delay for the selected audio output.	COMMAND #SCLR-AUDIO-DELAY?<scaler_index><CR> FEEDBACK ~nn@SCLR-AUDIO-DELAY<scaler_index>,delay<CR><LF>	scaler_index – Audio output number 1 – Scaler1 delay – 0 – Off 1 – 40ms 2 – 110ms 3 – 150ms	Get the scaler audio delay: #SCLR-AUDIO-DELAY?_1<CR>
SIGNAL?	Get input signal status.	COMMAND #SIGNAL?<in_index><CR> FEEDBACK ~nn@SIGNAL<in_index>,status<CR><LF>	in_index – Number that indicates the specific input: 1 – HDBT INPUT 2 – HDMI INPUT status – Signal status according to signal validation: 0 – Signal or sink is not valid (Off) 1 – Signal or sink is valid (On)	Get the input signal lock status of HDBT INPUT 1: #SIGNAL?_1<CR>
SN?	Get device serial number.	COMMAND #SN?<CR> FEEDBACK ~nn@SN<serial_num><CR><LF>	serial_num – 14 decimal digits, factory assigned	Get the device serial number: #SN?<CR>
VERSION?	Get firmware version number.	COMMAND #VERSION?<CR> FEEDBACK ~nn@VERSION<firmware_version><CR><LF>	firmware_version – XX.XX.XXXX where the digit groups are: major.minor.build version	Get the device firmware version number: #VERSION?<CR>
VFRZ	Set freeze on selected output.	COMMAND #VFRZ<out_index>,freeze_flag<CR> FEEDBACK ~nn@VFRZ<out_index>,freeze_flag<CR><LF>	out_index – Number that indicates the specific output: 1 – HDMI OUTPUT freeze_flag – On/Off 0 – Off 1 – On	Set freeze on HDMI OUTPUT: #VFRZ_1,1<CR>
VFRZ?	Get output freeze status.	COMMAND #VFRZ?<out_index><CR> FEEDBACK ~nn@VFRZ<out_index>,freeze_flag<CR><LF>	out_index – Number that indicates the specific output: 1 – HDMI OUTPUT freeze_flag – On/Off 0 – Off 1 – On	Get output freeze status: #VFRZ?_1<CR>
VID-RES	Set output resolution.  "Set" command with is_native=ON sets native resolution on selected output (resolution index sent = 0). Device sends as answer actual VIC ID of native resolution. To use "custom resolutions" (entries 100-105 In View Modes), define them using the DEF-RES command.	COMMAND #VID-RES<io_mode>,<io_index>,<is_native>,<resolution><CR> FEEDBACK ~nn@VID-RES<io_mode>,<io_index>,<is_native>,<resolution><CR><LF>	io_mode – Input/Output 1 – Output io_index – Number that indicates the specific output port: 1 – HDMI OUTPUT is_native – Native resolution flag 1 – On resolution – Resolution index 0=Native 1=640x480@60 2=800x600@60 3=1024x768@60 4=1280x768@60 5=1280x800@60 6=1280x1024@60 7=1360x768@60 8=1400x1050@60 9=1440x900@60 10=1600x1200@60 11=1680x1050@60 12=1920x1200@60 RB 13=2560x1600@60 RB 14=1920x1080@60 15=1280x720@60 16=2048x1080@50 17=2048x1080@60 18=2560x1440@60 RB 19=3440x1440@30 20=3440x1440@60 21=720x480P@60 22=720x576P@50 23=1280x720P@50 24=1280x720P@60 25=1920x1080P@24 26=1920x1080P@25 27=1920x1080P@30 28=1920x1080P@50 29=1920x1080P@60 30=2560x1080P@50 31=2560x1080P@60 32=3840x2160P@24 33=3840x2160P@25 34=3840x2160P@30 35=3840x2160P@50 36=3840x2160P@60	Set HDMI OUTPUT resolution to 1440x900: #VID-RES_1,1,1,9<CR>

Function	Description	Syntax	Parameters/Attributes	Example
VID-RES?	<p>Get output resolution.</p> <p>ⓘ "Get" command with is_native=ON returns native resolution VIC, with is_native=OFF returns current resolution. To use "custom resolutions" (entries 100-105 In View Modes), define them using the DEF-RES command.</p>	<p>COMMAND</p> <pre>#VID-RES?_io_mode,io_index,is_native<CR></pre> <p>FEEDBACK</p> <pre>~nn@VID-RES?_io_mode,io_index,is_native,resolution<CR><LF></pre>	<p>io_mode – Input/Output</p> <p>1 – Output</p> <p>io_index – Number that indicates the specific output port:</p> <p>1 – HDMI OUTPUT</p> <p>is_native – Native resolution flag</p> <p>1 – On</p> <p>resolution – Resolution index</p> <p>0=Native</p> <p>1=640x480@60</p> <p>2=800x600@60</p> <p>3=1024x768@60</p> <p>4=1280x768@60</p> <p>5=1280x800@60</p> <p>6=1280x1024@60</p> <p>7=1360x768@60</p> <p>8=1400x1050@60</p> <p>9=1440x900@60</p> <p>10=1600x1200@60</p> <p>11=1680x1050@60</p> <p>12=1920x1200@60 RB</p> <p>13=2560x1600@60 RB</p> <p>14=1920x1080@60</p> <p>15=1280x720@60</p> <p>16=2048x1080@50</p> <p>17=2048x1080@60</p> <p>18=2560x1440@60 RB</p> <p>19=3440x1440@30</p> <p>20=3440x1440@60</p> <p>21=720x480P@60</p> <p>22=720x576P@50</p> <p>23=1280x720P@50</p> <p>24=1280x720P@60</p> <p>25=1920x1080P@24</p> <p>26=1920x1080P@25</p> <p>27=1920x1080P@30</p> <p>28=1920x1080P@50</p> <p>29=1920x1080P@60</p> <p>30=2560x1080P@50</p> <p>31=2560x1080P@60</p> <p>32=3840x2160P@24</p> <p>33=3840x2160P@25</p> <p>34=3840x2160P@30</p> <p>35=3840x2160P@50</p> <p>36=3840x2160P@60</p>	<p>Set output resolution:</p> <pre>#VID-RES?_1,1,1<CR></pre>
VMUTE	<p>Set enable/disable video on output.</p> <p>ⓘ Video mute parameter 2 (blank picture) is not supported.</p>	<p>COMMAND</p> <pre>#VMUTE_out_index,flag<CR></pre> <p>FEEDBACK</p> <pre>~nn@VMUTE_out_index,flag<CR><LF></pre>	<p>out_index – Number that indicates the specific output:</p> <p>1 – HDMI OUTPUT</p> <p>flag – Video Mute</p> <p>0 – Video disabled, +5V low</p> <p>1 – Video enabled, +5V high</p> <p>2 – Blank picture, +5V high</p>	<p>Disable the video output on HDMI OUTPUT:</p> <pre>#VMUTE_1,0<CR></pre>
VMUTE?	<p>Get video on output status.</p> <p>ⓘ Video mute parameter 2 (blank picture) is not supported.</p>	<p>COMMAND</p> <pre>#VMUTE?_out_index<CR></pre> <p>FEEDBACK</p> <pre>~nn@VMUTE_out_index,flag<CR><LF></pre>	<p>out_index – Number that indicates the specific output:</p> <p>1 – HDMI OUTPUT</p> <p>flag – Video Mute</p> <p>0 – Video disabled, +5V low</p> <p>1 – Video enabled, +5V high</p> <p>2 – Blank picture, +5V high</p>	<p>Get video on HDMI OUTPUT status:</p> <pre>#VMUTE?_1<CR></pre>
X-AUD-LVL	<p>Set audio level of a specific signal.</p> <p>ⓘ This is an Extended Protocol 3000 command.</p>	<p>COMMAND</p> <pre>#X-AUD-LVL_<direction_type>.<port_format>.<port_index>.<signal_type>.<index>,audio_level<CR></pre> <p>FEEDBACK</p> <pre>~nn@X-AUD-LVL_<direction_type>.<port_format>.<port_index>.<signal_type>.<index>,audio_level<CR><LF></pre>	<p>The following attributes comprise the signal ID:</p> <ul style="list-style-type: none"> ▪ <direction_type> – Direction of the port: <ul style="list-style-type: none"> o OUT – Output ▪ <port_format> – Type of signal on the port: <ul style="list-style-type: none"> o ANALOG_AUDIO ▪ <port_index> – The port number as printed on the front or rear panel: 1 ▪ <signal_type> – Signal ID attribute: <ul style="list-style-type: none"> o AUDIO ▪ <index> – Indicates a specific channel number when there are multiple channels of the same type <p>audio_level – Audio level (range between 0 to +100)</p>	<p>Set the AUDIO OUT level to 10:</p> <pre>#X-AUD-LVL_out.analog_audio.1.audio.1,10<CR></pre>

Function	Description	Syntax	Parameters/Attributes	Example
X-AUD-LVL?	<p>Get audio level of a specific signal.</p> <p>i This is an Extended Protocol 3000 command.</p>	<p>COMMAND</p> <pre>#X-AUD-LVL?.<direction_type>.<port_format>.<port_index>.<signal_type>.<index><CR></pre> <p>FEEDBACK <pre>~nn@X-AUD-LVL.<direction_type>.<port_format>.<port_index>.<signal_type>.<index>,audio_level<CR><LF></pre> </p>	<p>The following attributes comprise the signal ID:</p> <ul style="list-style-type: none"> ▪ <direction_type> – Direction of the port: <ul style="list-style-type: none"> ○ OUT – Output ▪ <port_format> – Type of signal on the port: <ul style="list-style-type: none"> ○ ANALOG_AUDIO ▪ <port_index> – The port number as printed on the front or rear panel:1 ▪ <signal_type> – Signal ID attribute: <ul style="list-style-type: none"> ○ AUDIO ▪ <index> – Indicates a specific channel number when there are multiple channels of the same type <p>audio_level – Audio level (range between 0 to +100)</p>	<p>Get the audio level of a specific signal:</p> <pre>#X-AUD-LVL?_out.analog_audio.1.audio.1<CR></pre>
X-ROUTE	<p>Send routing command to matrix.</p> <p>i It is recommended to use the command #SIGNALS-LIST to get the list of all signal IDs available in the system and which can be used in this command.</p> <p>Video 1 is the default port in this command and is implied even if not written:</p> <pre>#X-ROUTE_out.sdi.5.in.sdi.1<CR></pre> <p>is interpreted as:</p> <pre>#X-ROUTE_out.sdi.5.video.1,in.sdi.1.video.1<CR></pre> <p>This is an Extended Protocol 3000 command.</p>	<p>COMMAND <pre>#X-ROUTE.<direction_type>.<port_type1>.<port_index1>.<signal_type1>.<index1>,<direction_type2>.<port_type2>.<port_index2>.<signal_type2>.<index2><CR></pre> <p>FEEDBACK <pre>~nn@X-ROUTE.<direction_type>.<port_type1>.<port_index1>.<signal_type1>.<index1>,<direction_type2>.<port_type2>.<port_index2>.<signal_type2>.<index2><CR><LF></pre> </p></p>	<p>The following attributes comprise the signal ID:</p> <ul style="list-style-type: none"> ▪ <direction_type> – Direction of the port: <ul style="list-style-type: none"> ○ IN – Input ○ OUT – Output ▪ <port_format> – Type of signal on the port: <ul style="list-style-type: none"> ○ HDMI ○ HDBT ▪ <port_index> – The port number as printed on the front or rear panel: <ul style="list-style-type: none"> For the output: 1 – HDMI OUTPUT For the input: 1 – HDBT INPUT 2 – HDMI INPUT ▪ <signal_type> – Signal ID attribute: <ul style="list-style-type: none"> ○ VIDEO ▪ <index> – Indicates a specific channel number when there are multiple channels of the same type: 1 	<p>Route HDMI INPUT to HDMI OUTPUT:</p> <pre>#X-ROUTE_out.hDMI.1.video.1,in.hDMI.2.video.1<CR></pre>
X-ROUTE?	<p>Get routing status.</p> <p>i It is recommended to use the command #SIGNALS-LIST to get the list of all signal IDs available in the system and which can be used in this command.</p> <p>VIDEO.1 are the default <signal_type> and <index> in this command and are implied even if not written:</p> <pre>#X-ROUTE_out.sdi.5.in.sdi.1<CR></pre> <p>is interpreted as:</p> <pre>#X-ROUTE_out.sdi.5.video.1,in.sdi.1.video.1<CR></pre> <p>This is an Extended Protocol 3000 command.</p>	<p>COMMAND <pre>#X-ROUTE?.<direction_type>.<port_type1>.<port_index1>.<signal_type1>.<index1><CR></pre> <p>FEEDBACK <pre>~nn@X-ROUTE.<direction_type>.<port_type1>.<port_index1>.<signal_type1>.<index1>,<direction_type2>.<port_type2>.<port_index2>.<signal_type2>.<index2><CR><LF></pre> </p></p>	<p>The following attributes comprise the signal ID:</p> <ul style="list-style-type: none"> ▪ <direction_type> – Direction of the port: <ul style="list-style-type: none"> ○ IN – Input ○ OUT – Output ▪ <port_format> – Type of signal on the port: <ul style="list-style-type: none"> ○ HDMI ○ HDBT ▪ <port_index> – The port number as printed on the front or rear panel: <ul style="list-style-type: none"> For the output: 1 – HDMI OUTPUT For the input: 1 – HDBT INPUT 2 – HDMI INPUT ▪ <signal_type> – Signal ID attribute: <ul style="list-style-type: none"> ○ VIDEO ▪ <index> – Indicates a specific channel number when there are multiple channels of the same type: 1 	<p>Get the routing status:</p> <pre>#X-ROUTE?_out.hDMI.1.video.1<CR></pre>

Function	Description	Syntax	Parameters/Attributes	Example
X-SIGNAL?	Get input signal status.  This is an Extended Protocol 3000 command.	COMMAND #X-SIGNAL? <direction_type>.<port_format>.<port_index>.<signal_type>.<index><CR> FEEDBACK ~nn X-SIGNAL? <direction_type>.<port_format>.<port_index>.<signal_type>.<index>,<status><CR><LF>	The following attributes comprise the signal ID: <ul style="list-style-type: none"> ▪ <direction_type> – Direction of the port: <ul style="list-style-type: none"> ○ IN – Input ▪ <port_format> – Type of signal on the port: <ul style="list-style-type: none"> ○ HDMI ○ HDBT ▪ <port_index> – The port number as printed on the front or rear panel: <ul style="list-style-type: none"> 1 – HDBT INPUT 2 – HDMI INPUT ▪ <signal_type> – Signal ID attribute: <ul style="list-style-type: none"> ○ VIDEO ▪ <index> – Indicates a specific channel number when there are multiple channels of the same type: 1 status – Input Signal Status 0 – No signal 1 – There is a signal	#X-SIGNAL? _in.hdbt.1.vid eo.1<CR>

Result and Error Codes

Syntax

In case of an error, the device responds with an error message. The error message syntax:

- **~NN@ERR XXX<CR><LF>** – when general error, no specific command
- **~NN@CMD ERR XXX<CR><LF>** – for specific command
- **NN** – machine number of device, default = 01
- **XXX** – error code

Error Codes

Error Name	Error Code	Description
P3K_NO_ERROR	0	No error
ERR_PROTOCOL_SYNTAX	1	Protocol syntax
ERR_COMMAND_NOT_AVAILABLE	2	Command not available
ERR_PARAMETER_OUT_OF_RANGE	3	Parameter out of range
ERR_UNAUTHORIZED_ACCESS	4	Unauthorized access
ERR_INTERNAL_FW_ERROR	5	Internal FW error
ERR_BUSY	6	Protocol busy
ERR_WRONG_CRC	7	Wrong CRC
ERR_TIMEDOUT	8	Timeout
ERR_RESERVED	9	(Reserved)
ERR_FW_NOT_ENOUGH_SPACE	10	Not enough space for data (firmware, FPGA...)
ERR_FS_NOT_ENOUGH_SPACE	11	Not enough space – file system
ERR_FS_FILE_NOT_EXISTS	12	File does not exist
ERR_FS_FILE_CANT_CREATED	13	File can't be created
ERR_FS_FILE_CANT_OPEN	14	File can't open
ERR_FEATURE_NOT_SUPPORTED	15	Feature is not supported
ERR_RESERVED_2	16	(Reserved)
ERR_RESERVED_3	17	(Reserved)
ERR_RESERVED_4	18	(Reserved)
ERR_RESERVED_5	19	(Reserved)
ERR_RESERVED_6	20	(Reserved)
ERR_PACKET_CRC	21	Packet CRC error
ERR_PACKET_MISSED	22	Packet number isn't expected (missing packet)
ERR_PACKET_SIZE	23	Packet size is wrong
ERR_RESERVED_7	24	(Reserved)
ERR_RESERVED_8	25	(Reserved)
ERR_RESERVED_9	26	(Reserved)
ERR_RESERVED_10	27	(Reserved)
ERR_RESERVED_11	28	(Reserved)
ERR_RESERVED_12	29	(Reserved)
ERR_EDID_CORRUPTED	30	EDID corrupted
ERR_NON_LISTED	31	Device specific errors
ERR_SAME_CRC	32	File has the same CRC – not changed
ERR_WRONG_MODE	33	Wrong operation mode
ERR_NOT_CONFIGURED	34	Device/chip was not initialized

The warranty obligations of Kramer Electronics Inc. ("Kramer Electronics") for this product are limited to the terms set forth below:

What is Covered

This limited warranty covers defects in materials and workmanship in this product.

What is Not Covered

This limited warranty does not cover any damage, deterioration or malfunction resulting from any alteration, modification, improper or unreasonable use or maintenance, misuse, abuse, accident, neglect, exposure to excess moisture, fire, improper packing and shipping (such claims must be presented to the carrier), lightning, power surges, or other acts of nature. This limited warranty does not cover any damage, deterioration or malfunction resulting from the installation or removal of this product from any installation, any unauthorized tampering with this product, any repairs attempted by anyone unauthorized by Kramer Electronics to make such repairs, or any other cause which does not relate directly to a defect in materials and/or workmanship of this product. This limited warranty does not cover cartons, equipment enclosures, cables or accessories used in conjunction with this product.

Without limiting any other exclusion herein, Kramer Electronics does not warrant that the product covered hereby, including, without limitation, the technology and/or integrated circuit(s) included in the product, will not become obsolete or that such items are or will remain compatible with any other product or technology with which the product may be used.

How Long this Coverage Lasts

The standard limited warranty for Kramer products is seven (7) years from the date of original purchase, with the following exceptions:

1. All Kramer VIA hardware products are covered by a standard three (3) year warranty for the VIA hardware and a standard three (3) year warranty for firmware and software updates; all Kramer VIA accessories, adapters, tags, and dongles are covered by a standard one (1) year warranty.
2. Kramer fiber optic cables, adapter-size fiber optic extenders, pluggable optical modules, active cables, cable retractors, ring mounted adapters, portable power chargers, Kramer speakers, and Kramer touch panels are covered by a standard one (1) year warranty. Kramer 7-inch touch panels purchased on or after April 1st, 2020 are covered by a standard two (2) year warranty.
3. All Kramer Calibre products, all Kramer Minicom digital signage products, all HighSecLabs products, all streaming, and all wireless products are covered by a standard three (3) year warranty.
4. All Sierra Video MultiViewers are covered by a standard five (5) year warranty.
5. Sierra switchers & control panels are covered by a standard seven (7) year warranty (excluding power supplies and fans that are covered for three (3) years).
6. K-Touch software is covered by a standard one (1) year warranty for software updates.
7. All Kramer passive cables are covered by a lifetime warranty.

Who is Covered

Only the original purchaser of this product is covered under this limited warranty. This limited warranty is not transferable to subsequent purchasers or owners of this product.

What Kramer Electronics Will Do

Kramer Electronics will, at its sole option, provide one of the following three remedies to whatever extent it shall deem necessary to satisfy a proper claim under this limited warranty:

1. Elect to repair or facilitate the repair of any defective parts within a reasonable period of time, free of any charge for the necessary parts and labor to complete the repair and restore this product to its proper operating condition. Kramer Electronics will also pay the shipping costs necessary to return this product once the repair is complete.
2. Replace this product with a direct replacement or with a similar product deemed by Kramer Electronics to perform substantially the same function as the original product. If a direct or similar replacement product is supplied, the original product's end warranty date remains unchanged and is transferred to the replacement product.
3. Issue a refund of the original purchase price less depreciation to be determined based on the age of the product at the time remedy is sought under this limited warranty.

What Kramer Electronics Will Not Do Under This Limited Warranty

If this product is returned to Kramer Electronics or the authorized dealer from which it was purchased or any other party authorized to repair Kramer Electronics products, this product must be insured during shipment, with the insurance and shipping charges prepaid by you. If this product is returned uninsured, you assume all risks of loss or damage during shipment. Kramer Electronics will not be responsible for any costs related to the removal or re-installation of this product from or into any installation. Kramer Electronics will not be responsible for any costs related to any setting up this product, any adjustment of user controls or any programming required for a specific installation of this product.

How to Obtain a Remedy Under This Limited Warranty

To obtain a remedy under this limited warranty, you must contact either the authorized Kramer Electronics reseller from whom you purchased this product or the Kramer Electronics office nearest you. For a list of authorized Kramer Electronics resellers and/or Kramer Electronics authorized service providers, visit our web site at www.kramerav.com or contact the Kramer Electronics office nearest you.

In order to pursue any remedy under this limited warranty, you must possess an original, dated receipt as proof of purchase from an authorized Kramer Electronics reseller. If this product is returned under this limited warranty, a return authorization number, obtained from Kramer Electronics, will be required (RMA number). You may also be directed to an authorized reseller or a person authorized by Kramer Electronics to repair the product.

If it is decided that this product should be returned directly to Kramer Electronics, this product should be properly packed, preferably in the original carton, for shipping. Cartons not bearing a return authorization number will be refused.

Limitation of Liability

THE MAXIMUM LIABILITY OF KRAMER ELECTRONICS UNDER THIS LIMITED WARRANTY SHALL NOT EXCEED THE ACTUAL PURCHASE PRICE PAID FOR THE PRODUCT. TO THE MAXIMUM EXTENT PERMITTED BY LAW, KRAMER ELECTRONICS IS NOT RESPONSIBLE FOR DIRECT, SPECIAL, INCIDENTAL OR CONSEQUENTIAL DAMAGES RESULTING FROM ANY BREACH OF WARRANTY OR CONDITION, OR UNDER ANY OTHER LEGAL THEORY. Some countries, districts or states do not allow the exclusion or limitation of relief, special, incidental, consequential or indirect damages, or the limitation of liability to specified amounts, so the above limitations or exclusions may not apply to you.

Exclusive Remedy

TO THE MAXIMUM EXTENT PERMITTED BY LAW, THIS LIMITED WARRANTY AND THE REMEDIES SET FORTH ABOVE ARE EXCLUSIVE AND IN LIEU OF ALL OTHER WARRANTIES, REMEDIES AND CONDITIONS, WHETHER ORAL OR WRITTEN, EXPRESS OR IMPLIED. TO THE MAXIMUM EXTENT PERMITTED BY LAW, KRAMER ELECTRONICS SPECIFICALLY DISCLAIMS ANY AND ALL IMPLIED WARRANTIES, INCLUDING, WITHOUT LIMITATION, WARRANTIES OF MERCHANTABILITY AND FITNESS FOR A PARTICULAR PURPOSE. IF KRAMER ELECTRONICS CANNOT LAWFULLY DISCLAIM OR EXCLUDE IMPLIED WARRANTIES UNDER APPLICABLE LAW, THEN ALL IMPLIED WARRANTIES COVERING THIS PRODUCT, INCLUDING WARRANTIES OF MERCHANTABILITY AND FITNESS FOR A PARTICULAR PURPOSE, SHALL APPLY TO THIS PRODUCT AS PROVIDED UNDER APPLICABLE LAW. IF ANY PRODUCT TO WHICH THIS LIMITED WARRANTY APPLIES IS A "CONSUMER PRODUCT" UNDER THE MAGNUSON-MOSS WARRANTY ACT (15 U.S.C.A. §2301, ET SEQ.) OR OTHER APPLICABLE LAW, THE FOREGOING DISCLAIMER OF IMPLIED WARRANTIES SHALL NOT APPLY TO YOU, AND ALL IMPLIED WARRANTIES ON THIS PRODUCT, INCLUDING WARRANTIES OF MERCHANTABILITY AND FITNESS FOR THE PARTICULAR PURPOSE, SHALL APPLY AS PROVIDED UNDER APPLICABLE LAW.

Other Conditions

This limited warranty gives you specific legal rights, and you may have other rights which vary from country to country or state to state.

This limited warranty is void if (i) the label bearing the serial number of this product has been removed or defaced, (ii) the product is not distributed by Kramer Electronics or (iii) this product is not purchased from an authorized Kramer Electronics reseller. If you are unsure whether a reseller is an authorized Kramer Electronics reseller, visit our web site at www.kramerav.com or contact a Kramer Electronics office from the list at the end of this document.

Your rights under this limited warranty are not diminished if you do not complete and return the product registration form or complete and submit the online product registration form. Kramer Electronics thanks you for purchasing a Kramer Electronics product. We hope it will give you years of satisfaction.



HDMI™
HIGH-DEFINITION MULTIMEDIA INTERFACE



P/N: 2900-301615

Rev: 1



SAFETY WARNING

Disconnect the unit from the power supply before opening and servicing

For the latest information on our products and a list of Kramer distributors, visit our website where updates to this user manual may be found.

We welcome your questions, comments, and feedback.

The terms HDMI, HDMI High-Definition Multimedia Interface, and the HDMI Logo are trademarks or registered trademarks of HDMI Licensing Administrator, Inc. All brand names, product names, and trademarks are the property of their respective owners.